

---

# Agilent Technologies E5500B Phase Noise Measurement System

## Installation Guide

---

Part number: E5500-90002  
Printed in USA  
June 2000  
Supersedes April 1998  
Manual Revision A.01.05

---

## Notice

The information contained in this document is subject to change without notice.

Agilent Technologies makes no warranty of any kind with regard to this material, including, but not limited to, the implied warranties of merchantability and fitness for a particular purpose. Agilent Technologies shall not be liable for errors contained herein or for incidental or consequential damages in connection with the furnishing, performance, or use of this material.

Agilent Technologies assumes no responsibility for the use or reliability of its software on equipment that is not furnished by Agilent Technologies.

This document contains proprietary information which is protected by copyright. All rights are reserved. No part of this document may be photocopied, reproduced, or translated to another language without prior written consent of Agilent Technologies.

### **U.S. Government Restricted Rights**

The Software and documentation are provided with "Restricted Rights". Use, duplication or disclosure by the U.S. Government is subject to the restrictions set forth in subparagraph (c)(1)(ii) of the Rights in Technical Data and Computer Software clauses in DFARS 252.227-7013 or as set forth in subparagraph (c)(1) and (2) of the Commercial Computer Software - Restricted Rights clauses at 48 CFR 52.227-19, as applicable. The Contractor for the Software is Agilent Technologies, 3000 Hanover Street, Palo Alto, California 94304.

### **Trademarks**

Windows NT 4.0™ is a U.S. trademarks of Microsoft Corp.

Pentium™ is a U.S. trademark of Intel Corporation

© Copyright Agilent Technologies 1997, 1998, 2000

Agilent Technologies  
Santa Rosa Systems Division  
1400 Fountaingrove Parkway  
Santa Rosa, CA 95403-1799, U.S.A.

# **AGILENT TECHNOLOGIES SOFTWARE LICENSE TERMS**

The following terms govern your use of the enclosed software programs ("Software") unless you have a separate written agreement with Agilent Technologies.

## **License Grant**

Agilent Technologies grants you a license to Use one copy of the version of the Software identified in your documentation on any one product. "Use" means storing, loading, installing, executing or displaying the Software. You may not modify the Software or disable any licensing or control features of the Software. Additional copies of the software may be used for the sole purpose of viewing previously measured data.

## **Ownership**

The Software is owned and copyrighted by Agilent Technologies or its third party licensors. Your license confers no title or ownership in the Software and should not be construed as a sale of any rights in the Software. Agilent Technologies' third party licensors may protect their rights in the event of any violation of these terms.

## **Copies and Adaptations**

You may only make copies or adaptations of the Software for archival purposes or when copying or adaptation is an essential step in the authorized use of the software. You must reproduce all copyright notices in the original Software on all authorized copies or adaptations. You may not copy the Software onto any bulletin board or similar system.

## **No Disassembly or Decryption**

You may not disassemble, decompile or decrypt the Software unless Agilent Technologies' prior written consent is obtained. In some jurisdictions, Agilent Technologies' consent may not be required for disassembly or decompilation. Upon request, you will provide Agilent Technologies with reasonably detailed information regarding any disassembly or decompilation.

## **Transfer**

Your license will automatically terminate upon any transfer of the Software. Upon transfer, you must deliver all copies of the Software and related documentation to the transferee. The transferee must accept these License Terms as a condition to the transfer.

## **Third Party Software**

Software may include third party software. Those third parties may protect their rights in the event of any violation of these License Terms.

## **Termination**

Agilent Technologies may terminate your license upon notice for failure to comply with any of these License Terms. Upon termination, you must immediately destroy the Software, together with all copies, adaptations and merged portions in any form.

## **Export Requirements**

You may not export or re-export the Software or any copy or adaptation in violation of any applicable laws or regulations.

---

## What You'll Find in This Manual...

- Chapter 1**
- E5500B Installation

---

## Limited Warranty

### Software

Agilent Technologies warrants that the software will perform substantially in accordance with the written materials for a period of one (1) year from the date of receipt.

Agilent Technologies does not warrant that the operation of the software will be uninterrupted or error free. In the event that this software product fails to execute its programming instructions during the warranty period, the customer's remedy shall be to return the media to Agilent Technologies for replacement. Should Agilent Technologies be unable to replace the media within a reasonable amount of time, Customer's alternate remedy shall be a refund of the purchase price upon return of all copies of the software.

### Media

Agilent Technologies warrants the media upon which this product is recorded to be free from defects in materials and workmanship under normal use for a period of one (1) year from the date of purchase. In the event any media prove to be defective during the warranty period, Customer's remedy shall be to return the media to Agilent Technologies for replacement. Should Agilent Technologies be unable to replace the media within a reasonable amount of time, Customer's alternate remedy shall be a refund of the purchase price upon return of the product and all copies.

### Notice of Warranty Claims

Customer shall notify Agilent Technologies in writing of any warranty claim not later than thirty (30) days after the expiration of the warranty period.

### Limitation of Warranty

Agilent Technologies makes no other express warranty, whether written or oral, with respect to this product.

Any implied warranty of merchantability or fitness is limited to one (1) year duration of this written warranty.

This warranty gives specific legal rights, and Customer may also have rights which vary which vary from state to state, or province to province.

### Exclusive Remedies

The remedies provided above are Customer's sole and exclusive remedies. In no event shall Agilent Technologies be liable for any direct, indirect, special, incidental, or consequential damages (including lost profit) whether based on warranty, contract, tort, or any other legal theory.

### Assistance

For assistance, call your local Agilent Technologies Sales and Service Office (refer to ["Service and Support" on page -vii](#)).

---

## Service and Support

Any adjustment, maintenance, or repair of this product must be performed by qualified personnel. Contact your customer engineer through your local Agilent Technologies Service Center. You can find a list of Agilent Technologies Service Centers on the web at

<http://www.agilent.com/find/tmdir>.

If you do not have access to the Internet, one of these Agilent Technologies centers can direct you to your nearest Agilent Technologies representative:

---

<b>United States:</b>	Agilent Technologies Test and Measurement Call Center PO Box 4026 Englewood, CO 80155-4026 (800) 452 4844 (toll-free in US)
<b>Canada:</b>	Agilent Technologies Canada Ltd. 5150 Spectrum Way Mississauga, Ontario L4W 5G1 (905) 206 4725
<b>Europe:</b>	Agilent Technologies European Marketing Centre Postbox 999 1180 AZ Amstelveen The Netherlands (31 20) 547 9900
<b>Japan:</b>	Yokogawa-Agilent Technologies Ltd. Measurement Assistance Center 9-1, Takakura-Cho, Hachioji-Shi Tokyo 192, Japan (81) 426 56 7832 (81) 426 56 7840 (FAX)
<b>Latin America:</b>	Agilent Technologies Latin American Region Headquarters 5200 Blue Lagoon Drive, 9th Floor Miami, Florida 33126, U.S.A. (305) 267 4245 (305) 267 4288 (FAX)
<b>Australia/New Zealand:</b>	Agilent Technologies Australia Ltd. 31-41 Joseph Street Blackburn, Victoria 3130 Australia 1 800 629 485 (toll-free)
<b>Asia-Pacific:</b>	Agilent Technologies Asia Pacific Ltd. 17-21/F Shell Tower, Times Square 1 Matheson Street, Causeway Bay Hong Kong (852) 2599 7777 (852) 2506 9285 (FAX)

---

Notice .....	ii
AGILENT TECHNOLOGIES SOFTWARE LICENSE TERMS .....	iii
What You'll Find in This Manual.....	v
Limited Warranty .....	vi
Software .....	vi
Media .....	vi
Notice of Warranty Claims .....	vi
Limitation of Warranty .....	vi
Exclusive Remedies .....	vi
Assistance .....	vi
Service and Support .....	vii

**1. Welcome to the E5500B Phase Noise Measurement System Series of Solutions**

What You'll Find in This Chapter.....	1-1
Introduction .....	1-3
System Requirements .....	1-4
Step 1. Unpacking Your System .....	1-5
Step 2. Installing the Hardware .....	1-6
Step 2a - Removing your Computer's Cover .....	1-7
Step 2b - Accessing your Computer's ISA Slots .....	1-8
Step 2c - Taking ESD Precautions .....	1-9
Step 2d- Installing the Interface Cards .....	1-10
Step 2e - Replacing the Computer Cover .....	1-13
Step 3. Installing the I/O Libraries .....	1-16
Step 3a - Installing the Agilent/HP I/O Libraries .....	1-16
Step 3b - Installing the Agilent/HP I/O Library Upgrade .....	1-17
Step 4. Installing the PC-Digitizer Software .....	1-19
Step 5. Installing the Windows NT 4.0 Service Pack .....	1-20
Step 6. Installing the Measurement Software .....	1-22
Step 7. Using the Asset Manager to Configure your System .....	1-23
Default GPIB Addresses .....	1-32
Step 8. Entering the License Key for the Phase Noise Test Set .....	1-33
Step 9. Starting the Measurement Software .....	1-36
Step 10. Using Server Hardware Connections to Specify Assets for the Confidence Test .....	1-37
Step 11. Running the Software Confidence Test .....	1-39
Beginning the Measurement .....	1-41
Making the Measurement .....	1-42
Congratulations .....	1-42



# 1

---

---

## Welcome to the E5500B Phase Noise Measurement System Series of Solutions

## What You'll Find in This Chapter...

- “Introduction” on page 1-3
- “System Requirements” on page 1-4
- “Step 1. Unpacking Your System” on page 1-5
- “Step 2. Installing the Hardware” on page 1-6
- “Step 3. Installing the I/O Libraries” on page 1-16
- “Step 4. Installing the PC-Digitizer Software” on page 1-19
- “Step 5. Installing the Windows NT 4.0“ Service Pack” on page 1-20
- “Step 6. Installing the Measurement Software” on page 1-22
- “Step 7. Using the Asset Manager to Configure your System” on page 1-23
- “Step 8. Entering the License Key for the Phase Noise Test Set” on page 1-33
- “Step 9. Starting the Measurement Software” on page 1-36
- “Step 10. Using Server Hardware Connections to Specify Assets for the Confidence Test” on page 1-37
- “Step 11. Running the Software Confidence Test” on page 1-39

---

## Introduction

This installation guide will take you through the process of installing both the hardware (if you did not order a preconfigured system from Agilent Technologies) and the E5500 Phase Noise Software. A confidence test is also included as the last step in the installation procedure.

**Table 1** *Installation Steps*

<b>If you ordered a preconfigured system, do these steps:</b>	<b>If you ordered an Option 1FF (delete computer), do these steps:</b>
<b>Skip</b> "System Requirements" on page 1-4	Read "System Requirements" on page 1-4
"Step 1. Unpacking Your System" on page 1-5	"Step 1. Unpacking Your System" on page 1-5
<b>Skip Steps 2 to 8</b>	"Step 2. Installing the Hardware" on page 1-6
	"Step 3. Installing the I/O Libraries" on page 1-16
	"Step 4. Installing the PC-Digitizer Software" on page 1-19
	"Step 5. Installing the Windows NT 4.0 " Service Pack" on page 1-20
	"Step 6. Installing the Measurement Software" on page 1-22
	"Step 7. Using the Asset Manager to Configure your System" on page 1-23
	"Step 8. Entering the License Key for the Phase Noise Test Set" on page 1-33
"Step 9. Starting the Measurement Software" on page 1-36	"Step 9. Starting the Measurement Software" on page 1-36
"Step 10. Using Server Hardware Connections to Specify Assets for the Confidence Test" on page 1-37	"Step 10. Using Server Hardware Connections to Specify Assets for the Confidence Test" on page 1-37
"Step 11. Running the Software Confidence Test" on page 1-39	"Step 11. Running the Software Confidence Test" on page 1-39

## System Requirements

The setup program in the E5500 Phase Noise Measurement Software makes installation easy. In case you want a quick review of the system requirements, we have listed them first.

The system requirements for the phase noise measurement software are:

- Pentium<sup>®</sup> microprocessor (100 MHz or higher recommended)
- 32 megabytes (MB) of memory (RAM)
- 1 gigabyte (GB) hard disk
- Super Video Graphics Array (SVGA)
- 2 additional 16-bit ISA slots available for the phase noise system hardware.
  - 1 for PC-Digitizer
  - 1 for GPIB Interface Card
- Windows NT 4.0<sup>®</sup>
- Windows NT 4.0 Service Pack 4 or greater
- IEEE-488 GPIB Interface Card (Agilent/HP 82341C GPIB Interface Card)

---

## Step 1. Unpacking Your System

1. Unpack and inspect the shipping container and its contents thoroughly to ensure that nothing was damaged during shipment.

If the container or packing material is damaged, the contents should be checked both mechanically and electrically. If the contents are damaged or defective, contact your nearest Agilent Technologies Sales and Service office. Keep the shipping materials for the carrier's inspection.

2. Verify that all parts and materials were included in the shipping container:
  - E5500 Phase Noise Measurement System CD-ROM
  - E5500 Software Keyword Licence Certificate
  - E5500 User's Guide
  - E5500B Installation Guide
  - 9300-1408 Disposable Grounding Strap (Option 1FF)
  - 5957-4369 Electrostatic Discharge (ESD) Warning Pamphlet
  - PC-Digitizer Card (Option 1FF)

*Table 1-2 Connectors and Adapters*

Part Number	Description	Agilent/HP 70420A	Agilent/HP 70420A Option 001	Agilent/HP 70420A Option 201	Agilent/HP 70422A
1250-0207	BNC, 50 ohm Termination	1	1	1	
1250-0780	Adapter, N(m) - BMC(f)	3	2	3	1
1250-1250	Adapter, N(m) - SMA(f)		1		2
1250-2015	Adapter, SMA(f) - BNC(m)				1
5061-5311	Adapter/Saver, 3.5mm(f) - 3.5mm(f)		2	2	
1250-1200	Adapter, SMA(m) - BNC(f)		2		

## Step 2. Installing the Hardware

---

### NOTE

---

If you have ordered a preconfigured phase noise system from Agilent Technologies, skip this step and proceed to [“Step 9. Starting the Measurement Software”](#) on page 1-36.

Installing the phase noise hardware into your computer involves the following steps:

[“Step 2a - Removing your Computer’s Cover”](#) on page 1-7

[“Step 2b - Accessing your Computer’s ISA Slots”](#) on page 1-8

[“Step 2c - Taking ESD Precautions”](#) on page 1-9

[“Step 2d- Installing the Interface Cards”](#) on page 1-10

[“Step 2e - Replacing the Computer Cover”](#) on page 1-13

## Step 2a - Removing your Computer's Cover

---

**CAUTION**

---

Refer to your computer's documentation for installation safety instructions and specific instructions for opening your computer.

Use the following steps to install the GPIB and PC-Digitizer cards in your computer:

3. Power down the computer and all its peripherals.
4. Disconnect the power cord from the computer.
5. Unlock and remove the cover from the computer. This gives access to the I/O slots. (See your computer documentation for detailed instructions.)

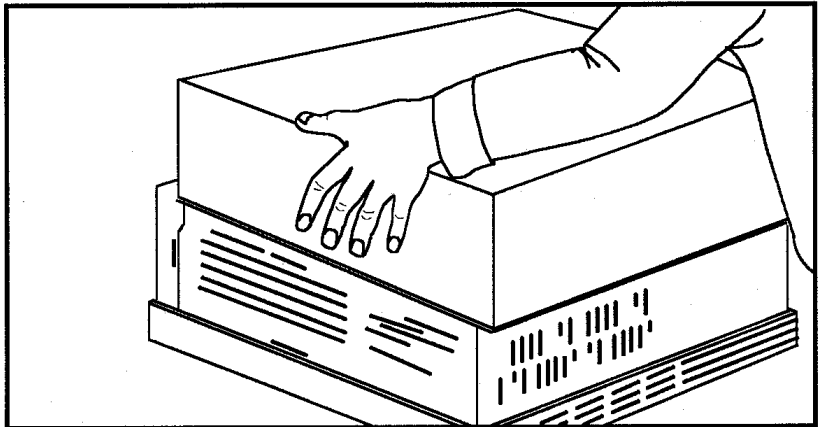

## Step 2b - Accessing your Computer's ISA Slots

6. Look for suitable ISA expansion slots for both the GPIB and PC-Digitizer cards and remove the back panel's cover plates. Choose slots that give good access to the GPIB and PC-Digitizer connectors.

The following drawing shows a view of the ISA slots vertically mounted; your computer's ISA slots may be horizontally mounted, but the process is the same.

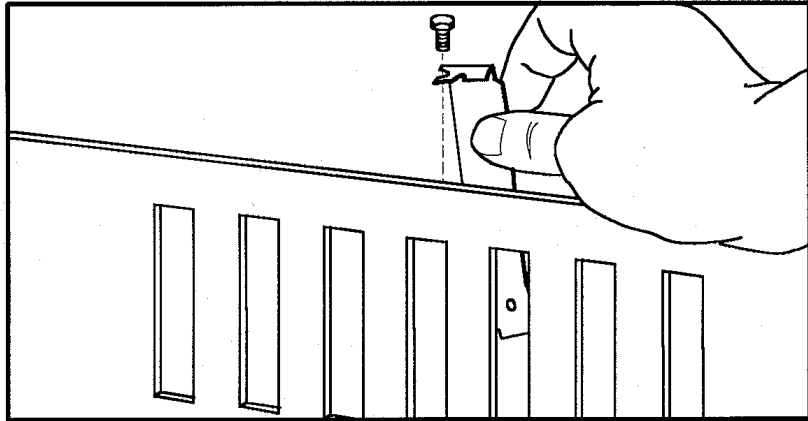



## Step 2c - Taking ESD Precautions

---

### CAUTION

---

To prevent possible ESD damage, you must be properly grounded with a grounding wrist strap before touching the PC-Digitizer or GPIB (customer supplied) Interface Cards. While inserting the cards, be sure to hold the cards by their edges.

7. Using the disposable grounding strap, supplied with the PC-Digitizer interface card, unwrap the first two folds of the wrist strap and wrap the exposed adhesive side firmly around your wrist.

---

### CAUTION

---

Wear this grounding wrist strap before unpacking or touching the PC-Digitizer or GPIB interface cards; it is provided for control of static electricity. Failure to use the grounding wrist strap properly can result in damage to electronic devices and assemblies

8. Unroll the rest of the wrist strap and peel the liner from the copper foil at the opposite end.
9. Attach the copper foil to a convenient and exposed electrical ground somewhere on the computer's chassis. This should be an unpainted surface of the computer cabinet.

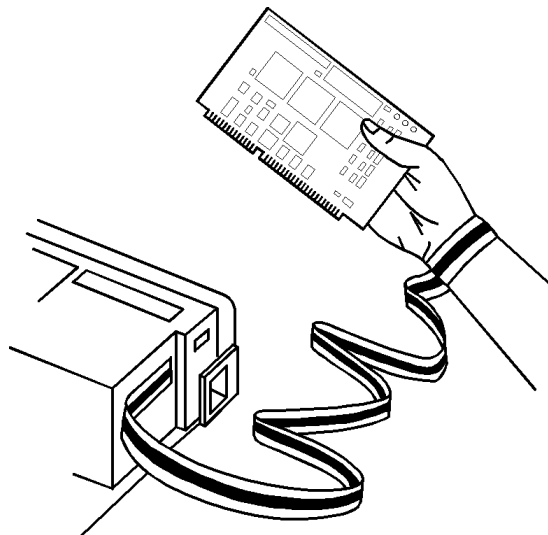

## Step 2d- Installing the Interface Cards

### Installing the GPIB Interface Card

10. Insert the GPIB interface edge connector into the expansion slot connector of the computer. Make sure the interface is fully seated by pushing firmly on the edge of the card with the palm of your hand. The GPIB connector should extend through the back panel opening to allow cable installation.

---

#### NOTE

---

Use of a GPIB connector extender may be necessary for adequate clearance between the GPIB cable and the computer chassis.

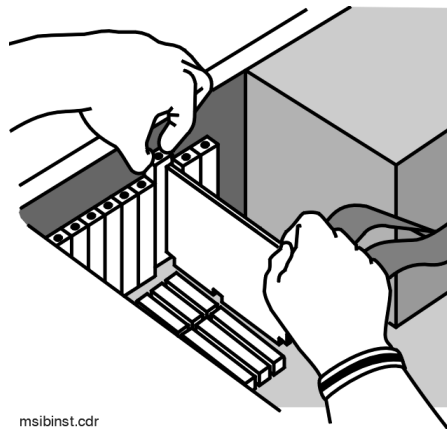

11. Replace the GPIB back-panel cover plate screw to hold the interface in place. (Save the blank cover plate for use if the interface is removed later.)

## Installing the PC-Digitizer Interface Card

- Verify the following jumper and DIP switch settings prior to installing the PC-Digitizer interface card.

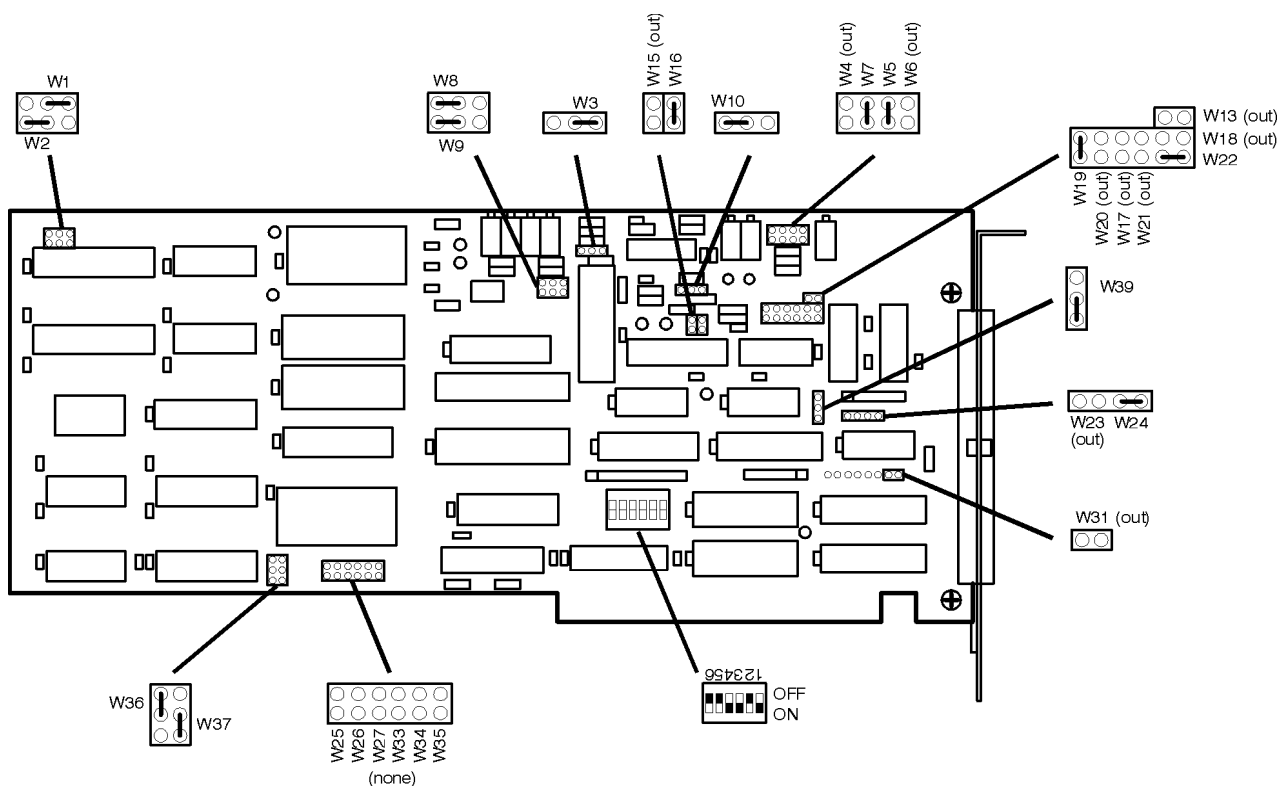

/E5500/90002/art/jumpers.cdr

- Insert the PC-Digitizer interface edge connector into the expansion slot connector of the computer. Make sure the interface is fully seated by pushing firmly on the edge of the card with the palm of your hand.

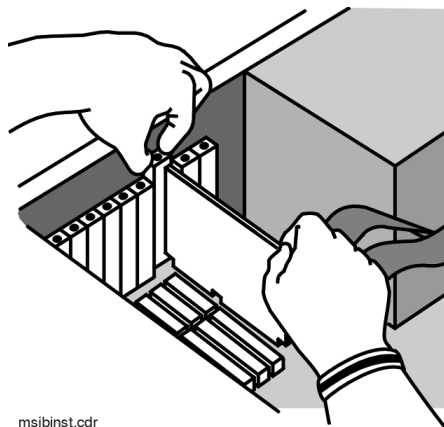

msibinst.cdr

Welcome to the E5500B Phase Noise Measurement System Series of Solutions

14. Replace the PC-Digitizer back-panel cover plate screw to hold the interface in place. (Save the blank cover plate for use if the interface is removed later.
15. Replace the computer's cover as described in you computer's documentation.

**Installing the Digitizer Adapter.**

16. Connect the Digitizer Adapter to the back of the PC-Digitizer interface card.

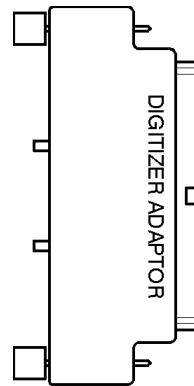

adapter.cdr

## Step 2e - Replacing the Computer Cover

17. Replace the computer cover as described in your computer's documentation.

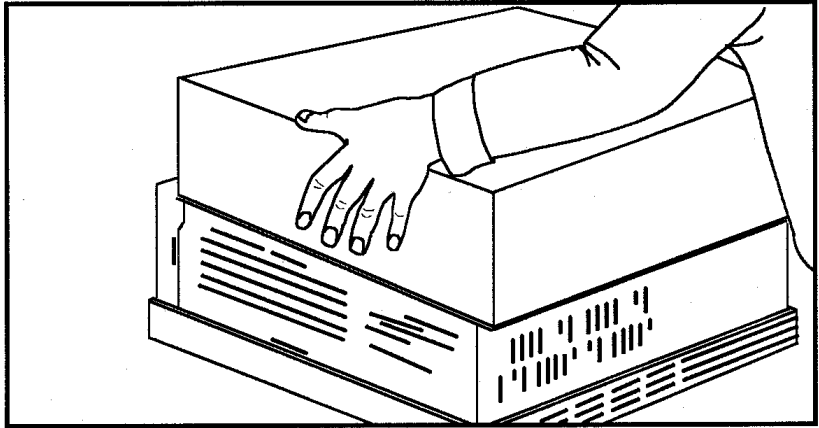

18. Connect the following cables between the PC digitizer and the Agilent/HP 70420A Test Set:
  - SMB (f) to BNC (m) cable between the PC digitizer interface card adapter's input connector and the Agilent/HP 70420A Test Set's front-panel <100 kHz output connector.
  - SMB (f) to BNC (m) cable between the PC digitizer interface card adapter's output connector and the Agilent/HP 70420A Test Set's rear-panel Noise Source Input connector.
19. Refer to the following system connect diagram examples for more information about system interconnections:
  - [“E5501B Connect Diagram Example” on page 1-14](#)
  - [“E5502B/3B/4B Connect Diagram Example” on page 1-15](#)

### E5501B Connect Diagram Example

#### E5501B Phase Noise System

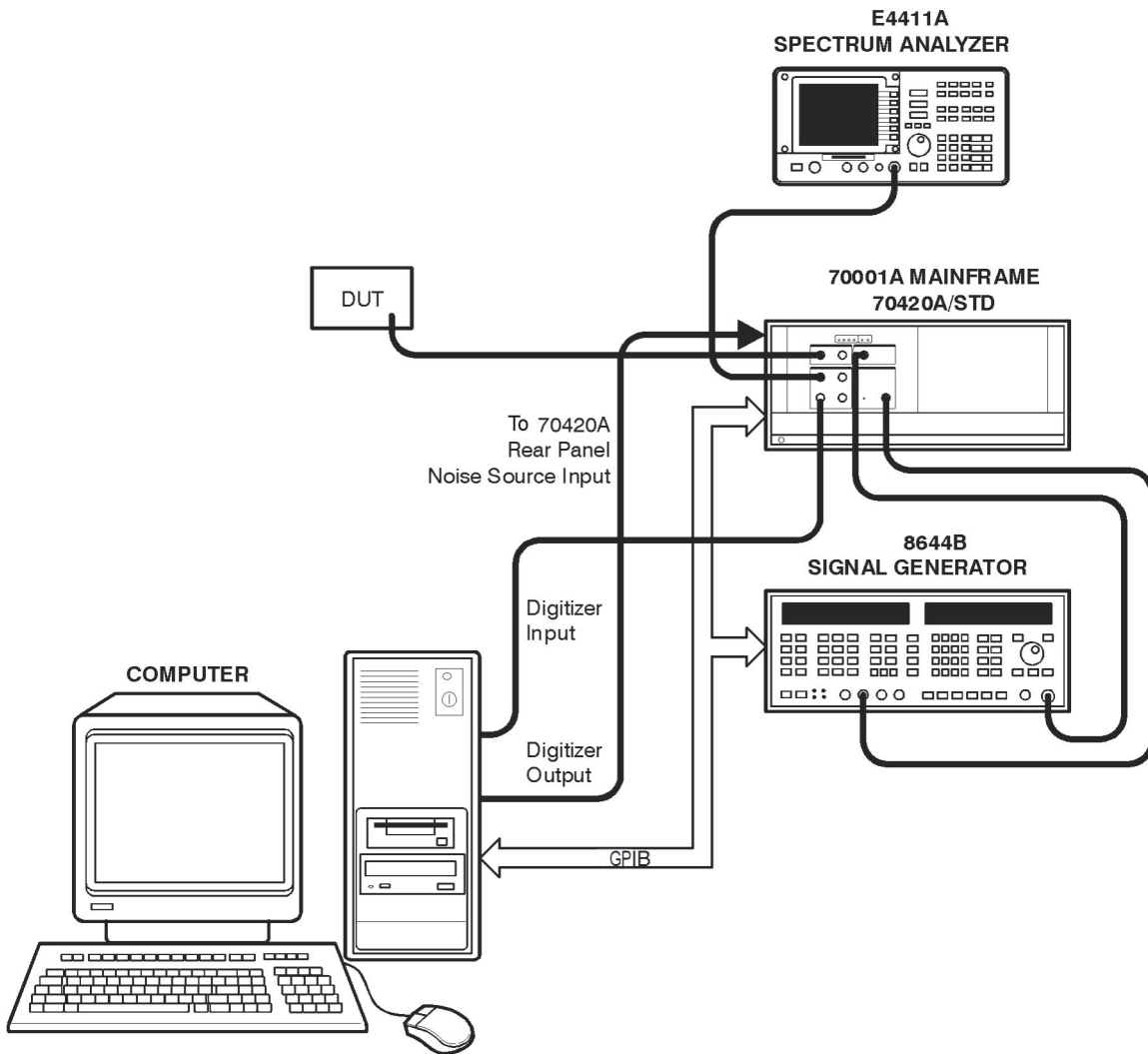

e5500/90004/art/ts2.pcx

### E5502B/3B/4B Connect Diagram Example

E5502B/3B/4B Phase Noise System

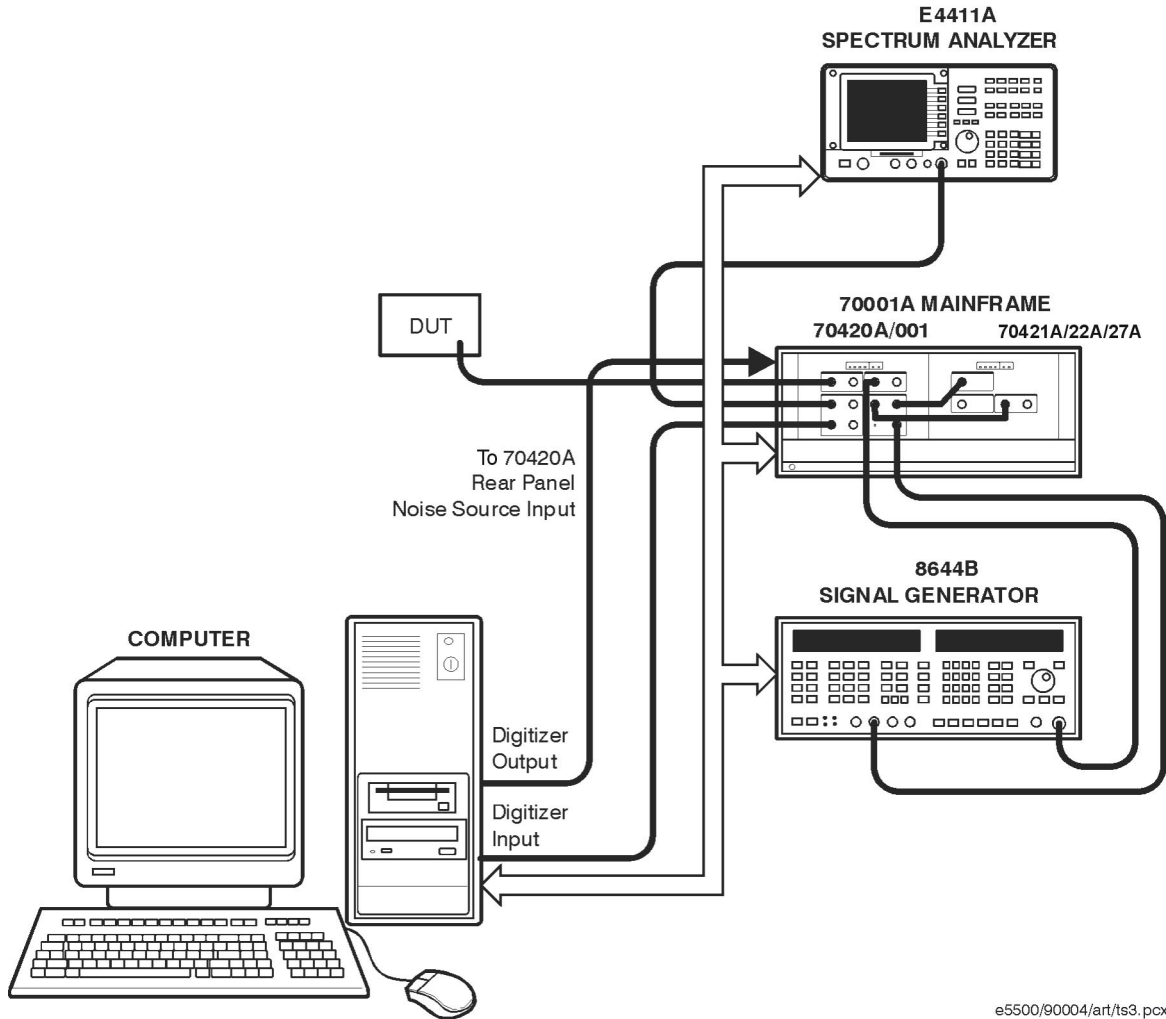

e5500/90004/art/ts3.pcx

---

## Step 3. Installing the I/O Libraries

---

### NOTE

If you have ordered a preconfigured phase noise system from Agilent Technologies, skip this step and proceed to [“Step 9. Starting the Measurement Software”](#) on page 1-36.

Installing the I/O libraries involves the following steps:

- **Step 3a - Installing the Agilent/HP I/O Libraries**, page 1-16
- **Step 3b - Installing the Agilent/HP I/O Library Upgrade**, page 1-17

---

### NOTE

If, for any reason, the Agilent/HP I/O libraries must be re-installed at a later date, the E5500 Measurement software (Step 6.) must also be re-installed **after** the I/O Library installation.

---

### Step 3a - Installing the Agilent/HP I/O Libraries

1. Make sure your computer and monitor are turned on.
2. Place the E5500 Phase Noise Measurement Software CD-ROM in the CD-ROM drive.
3. The following dialog box will appear.

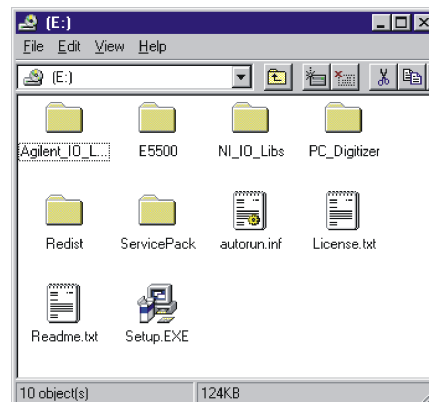



4. Double-click on **Agilent\_IO\_libs**, then on **Setup.exe** and follow the instructions (accept the default settings).

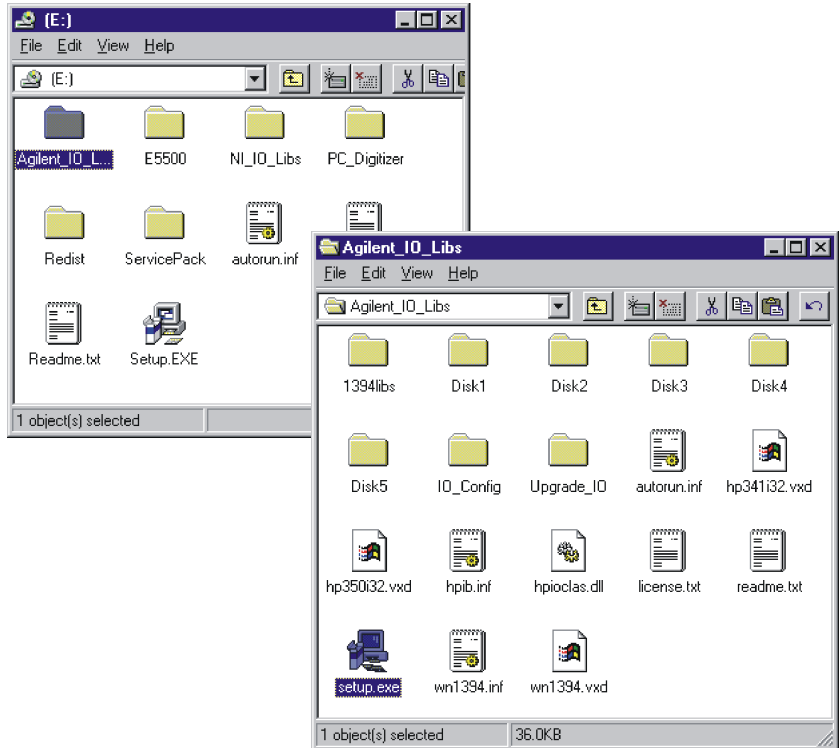

---

**NOTE**

---

When offered the choice, do **not** restart your computer at this time.

### Step 3b - Installing the Agilent/HP I/O Library Upgrade

1. Make sure your computer and monitor are turned on.
2. Place the E5500 Phase Noise Measurement Software CD-ROM in the CD-ROM drive.
3. The following dialog box will appear.

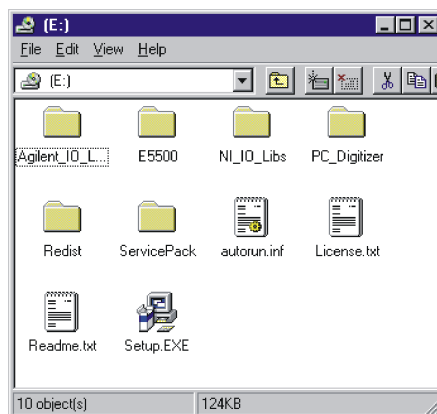

Welcome to the E5500B Phase Noise Measurement System Series of Solutions

4. Double-click on **Agilent\_IO\_libs**, **Upgrade\_IO**, then on **Install.exe** and follow the instructions in the Readme.txt file.

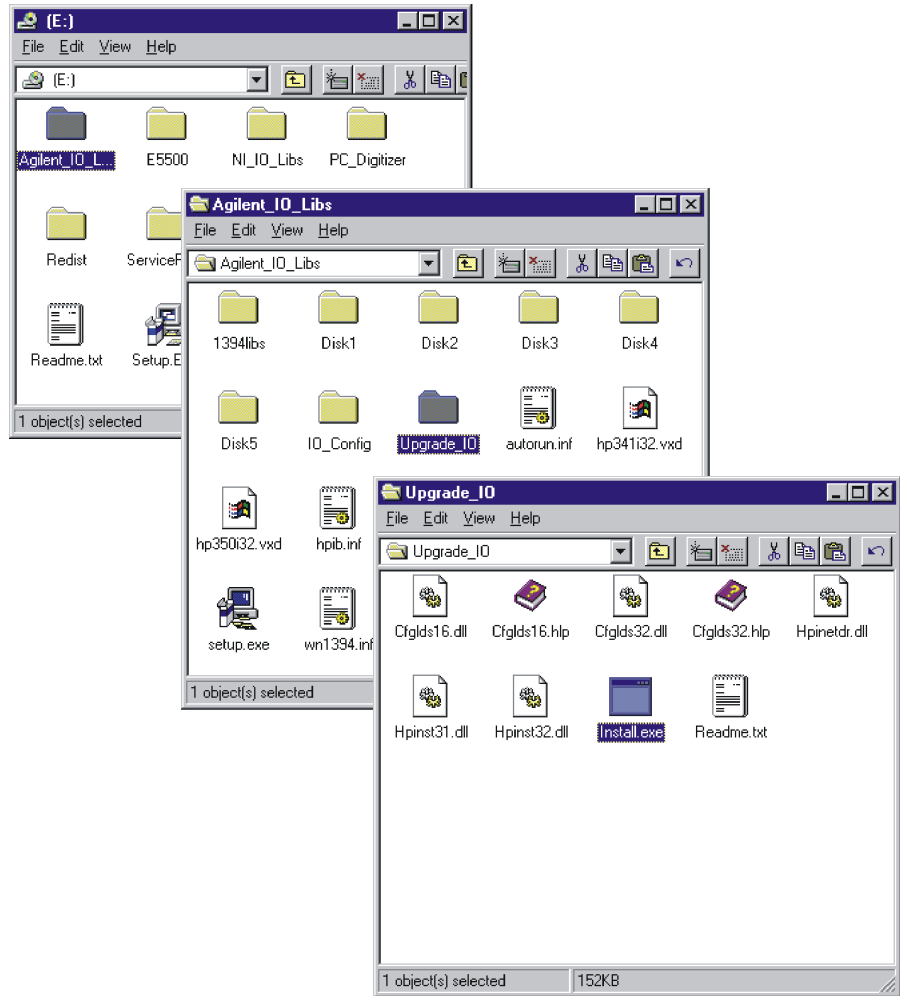

---

**NOTE**

---

When offered the choice, do **not** restart your computer at this time.

---

## Step 4. Installing the PC-Digitizer Software

---

### NOTE

If you have ordered a preconfigured phase noise system from Agilent Technologies, skip this step and proceed to [“Step 9. Starting the Measurement Software”](#) on page 1-36.

1. Make sure your computer and monitor are turned on.
2. Place the E5500 Phase Noise Measurement Software CD-ROM in the CD-ROM drive.
3. The following dialog box will appear.

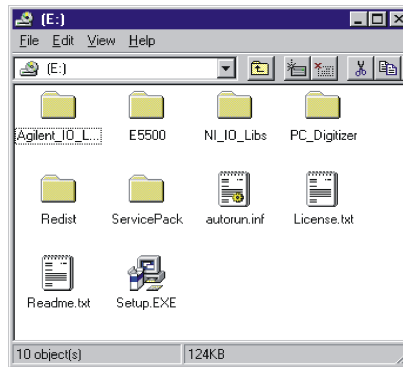

4. Double-click on **PC\_Digitizer**, then on **Setup.exe** and follow the instructions (accept the default settings).

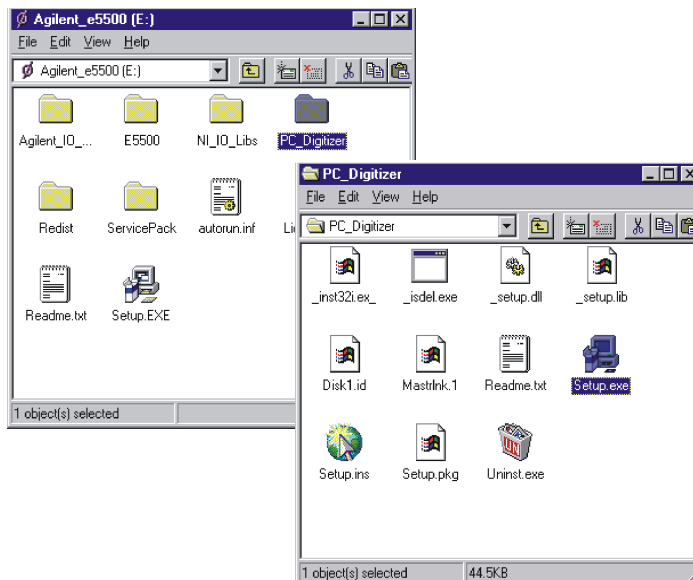

---

### NOTE

When offered the choice, do **not** restart your computer at this time.

---

## Step 5. Installing the Windows NT 4.0® Service Pack

---

### NOTE

If you have ordered a preconfigured phase noise system from Agilent Technologies, skip this step and proceed to “[Step 9. Starting the Measurement Software](#)” on page 1-36.

1. Make sure your computer and monitor are turned on.
2. Place the E5500 Phase Noise Measurement Software CD-ROM in the CD-ROM drive.
3. The following dialog box will appear.

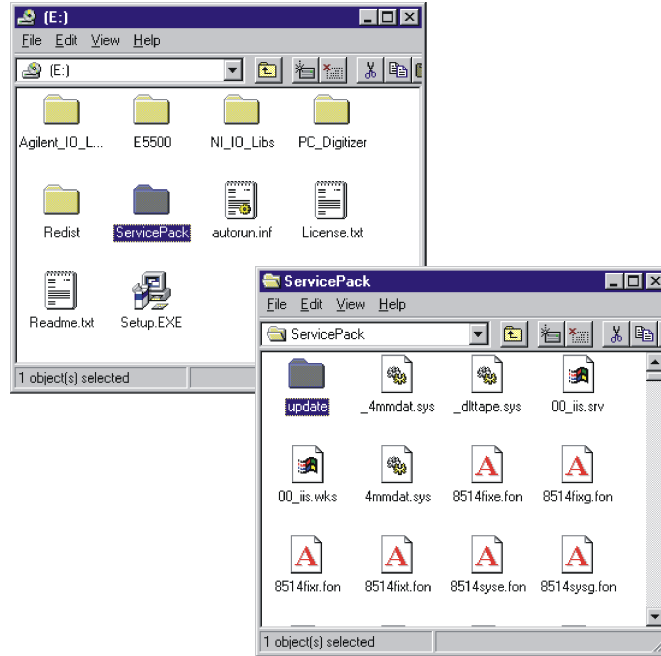

4. Double-click on **Service Pack**, then on **Update.exe** and follow the instructions (accept the default settings).

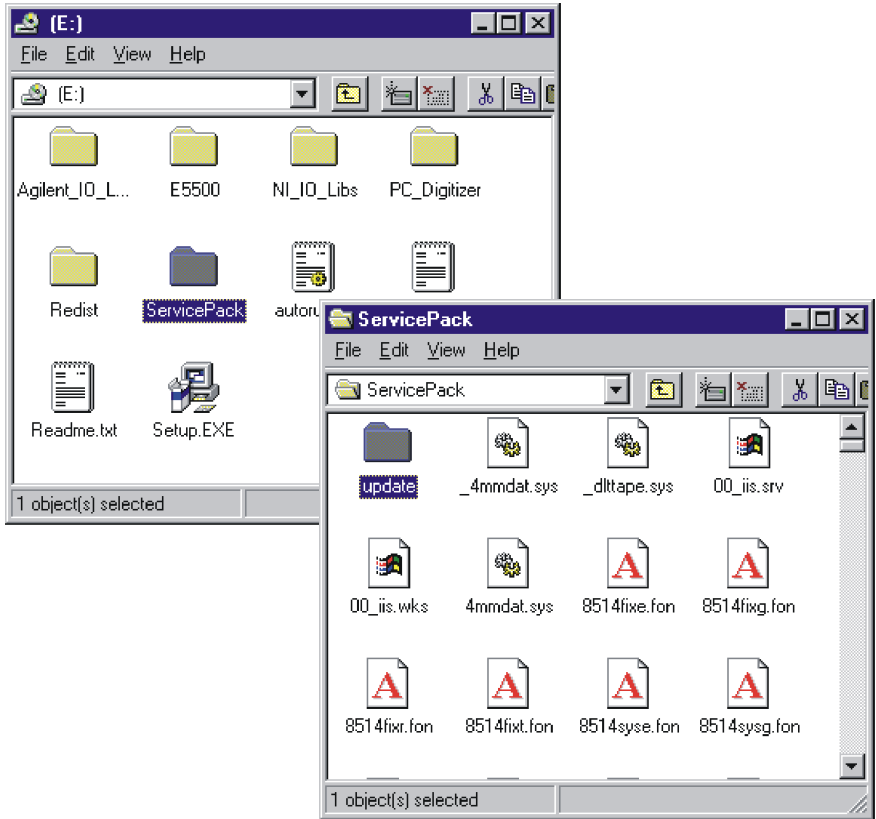

5. **Reboot** your computer at this time.

---

## Step 6. Installing the Measurement Software

---

### NOTE

If you have ordered a preconfigured phase noise system from Agilent Technologies, skip this step and proceed to [“Step 9. Starting the Measurement Software”](#) on page 1-36.

1. Make sure your computer and monitor are turned on.
2. Place the E5500 Phase Noise Measurement Software CD-ROM in the CD-ROM drive.
3. The following dialog box will appear. Double click on **Setup.exe** and follow the instructions (accept the default settings).

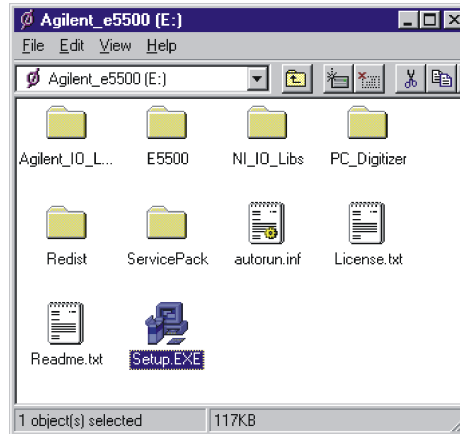

---

## Step 7. Using the Asset Manager to Configure your System

The following procedure will configure both the Agilent/HP 70420A Phase Noise Test Set and PC-Digitizer so they can be used in the E5500A Phase Noise Measurement System to make measurements.

---

### NOTE

If you have ordered a preconfigured phase noise system from Agilent Technologies, skip this step and proceed to [“Step 9. Starting the Measurement Software”](#) on page 1-36.

1. Make sure your computer and monitor are turned on.
2. Place the E5500 Phase Noise Measurement Software CD-ROM in the CD-ROM drive.
3. Click the **Start** button, point to **Programs**, point to **Agilent Subsystems**, point to **E5500 Phase Noise**, and then click **E5500 Asset Manager**.

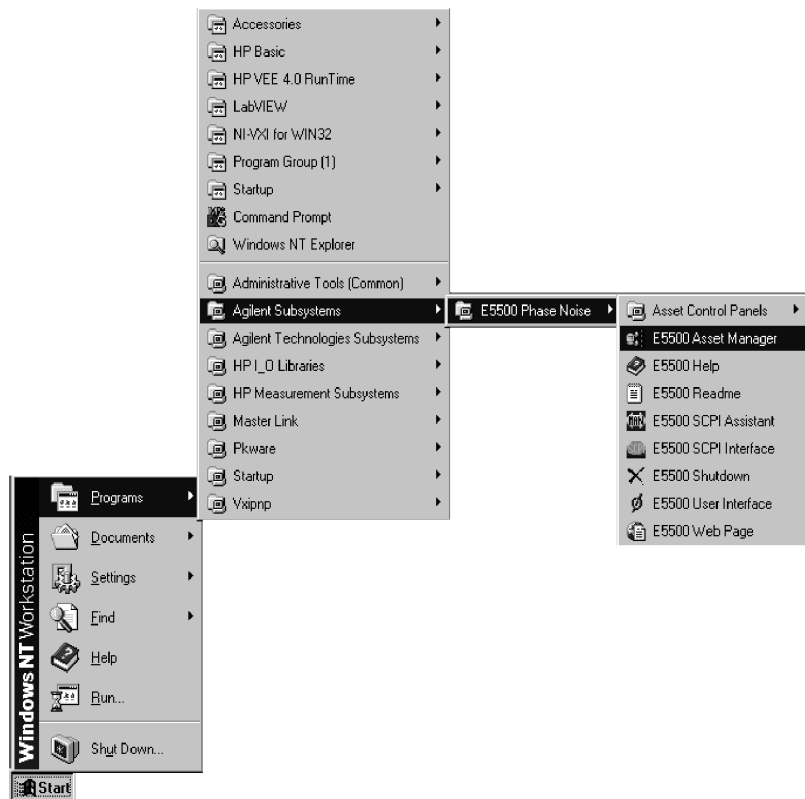

## Welcome to the E5500B Phase Noise Measurement System Series of Solutions

- To place the Asset Manager in non-demo mode, click **Options**, and then click **Demo Mode** to unselect Demo Mode.

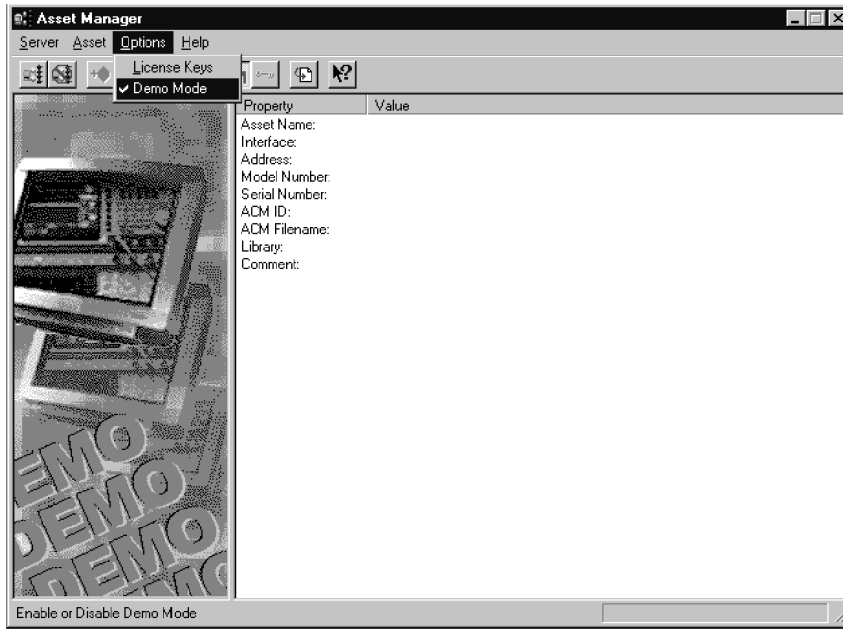

- Click **OK**. The Asset Manager can be invoked from within the phase noise measurement software, and if that were the case you would need to restart the software for any changes made in the Asset Manager to take effect.

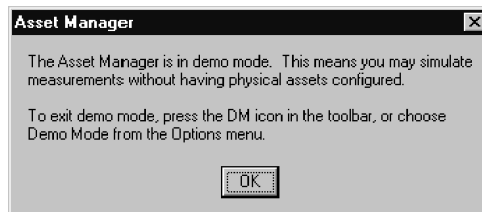

### Configuring the Agilent/HP 70420A Test Set

- Click the **Asset Wizard** button to start configuring the Agilent/HP 70420A Phase Noise Test Set using the Asset Manager Asset Wizard.





Welcome to the E5500B Phase Noise Measurement System Series of Solutions

- From the **Asset Type** pull-down list, select **Test Set**, then click the **Next** button.

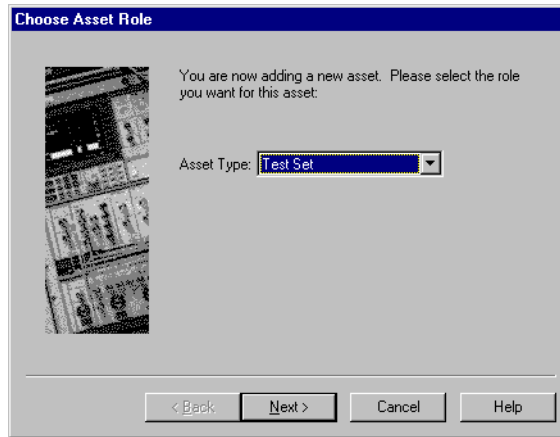

- Click on **Agilent/HP 70420**, then click the **Next** button.

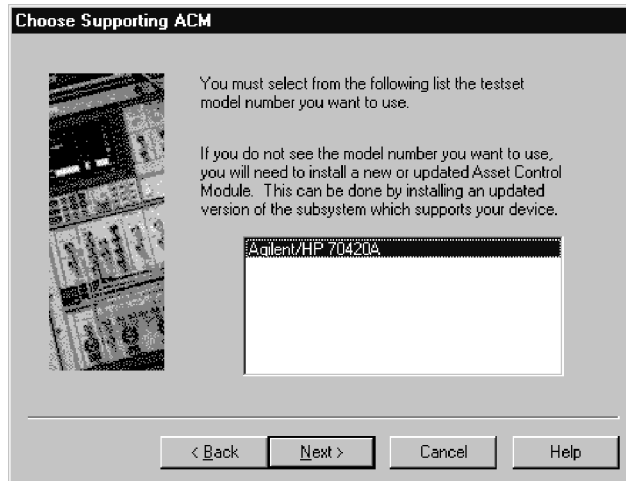

- From the **Interface** pull-down list, select **GPIB0**.
- In the **Address** box, type **20**. 20 is the default address for the Agilent/HP 70420A phase noise test set. For a list of default addresses, refer to [Table 1-3 on page 1-32](#).

The **Library** pull-down list does not apply to this example. It applies specifically to either the Agilent Technologies GPIB or the National GPIB interface cards.

# Welcome to the E5500B Phase Noise Measurement System Series of Solutions

11. Click the **Next** button.

**Select Interface and Address**

You will now need to select the interface through which you will talk to the asset and the asset's address on that interface:

Interface: GPIB0

Address: 20

Library: Agilent Technologies VISA

< Back   Next >   Cancel   Help

12. In the **Asset Name** box, type **Agilent/HP 70420A**.

13. In the **Serial Number (optional)** box, type the serial number for your Agilent/HP 70420A test set. Click the **Next** button.

**Set Model & Serial Numbers**

You will need to enter your asset's name and serial number:

Asset Name: Agilent/HP 70420A

Serial Number (optional): 123456

< Back   Next >   Cancel   Help

14. You may type a comment in this dialog box. The comment will associate itself with the asset you have just configured. Click the **Finish** button.

**Enter A Comment**

Congratulations! You have added a new asset to your asset server. If you would like, you may enter an asset comment for your own use.

Once you return to the main screen, you may also want to perform an I/D check on this asset. You can do this by using the check mark icon.

Comment: You can type a comment here

< Back   Finish   Cancel   Help

15. The following dialog box will appear.

The left pane shows either the demo mode, or in this case, a list of assets or asset roles. An asset is any piece of hardware (Agilent/HP 70420A) that you want configured for system use. An asset role is the general category for hardware (test sets, downconverters, counters, for example). The right pane is information only. The information can be changed by double-clicking a specific asset.

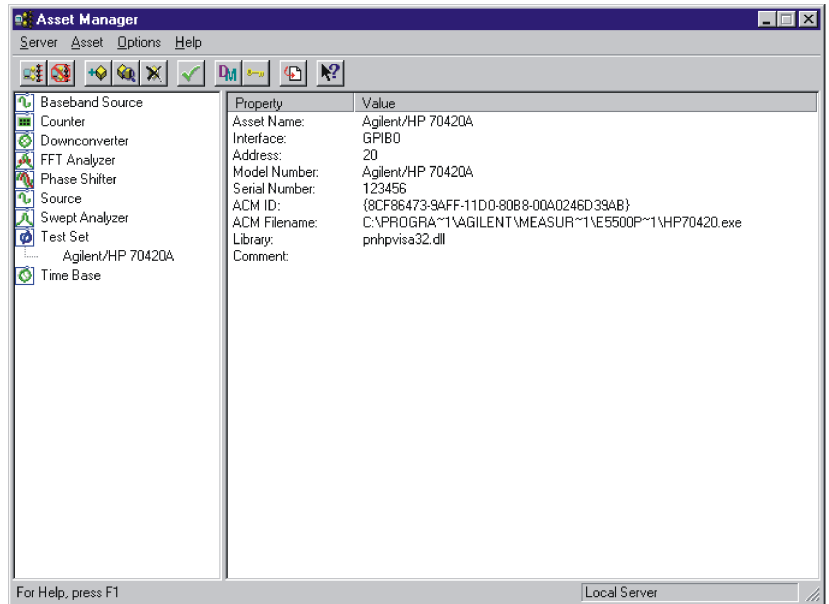

You have just used the Asset Manager to configure the Agilent/HP 70420A test set. The process for configuring any asset is essentially the same. As a second example, we will now configure the PC-Digitizer. Both the test set and PC-digitizer are required to perform the confidence test at the end of this chapter.

### Configuring the PC Digitizer

For this example we will use invoke the Asset Manager Wizard from within the Asset Manager. This is the most common way to add assets.

Welcome to the E5500B Phase Noise Measurement System Series of Solutions

16. click **Asset**, and then click **Add**.

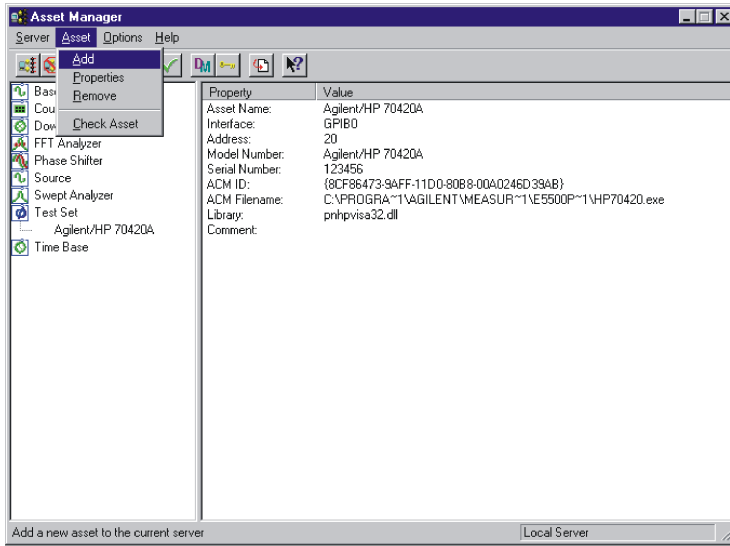

17. From the **Asset Type** pull-down list, select **FFT Analyzer**, then click the **Next** button.



18. Click on **II PCI20428W-1**, then click the **Next** button.

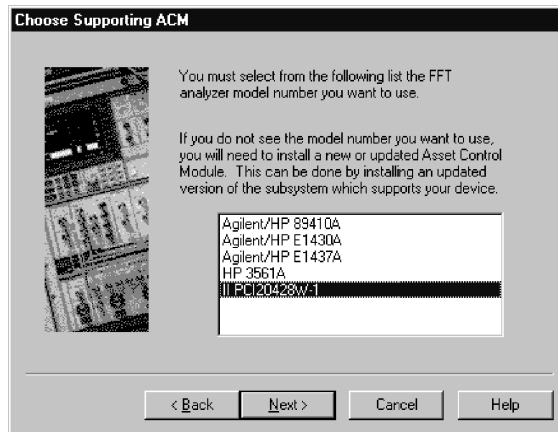

19. From the **Interface** pull-down list, select **PCI**.

20. In the **Address** box, type **320**. 320 is the default address for the II20428 PC-Digitizer.

The **Library** pull-down list does not apply to this example. It applies specifically to either the Agilent GPIB or the National GPIB interface cards.

21. Click the **Next** button.

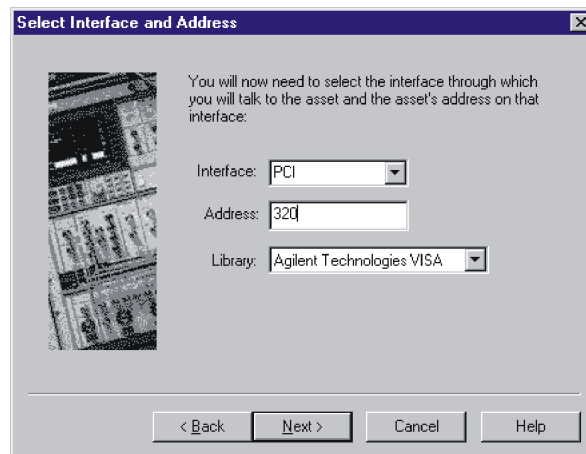

22. In the **Asset Name** box, type **II PCI20428W-1**.

Welcome to the E5500B Phase Noise Measurement System Series of Solutions

23. In the **Serial Number** box (optional), type the serial number for your PC-digitizer. Click the **Next** button.

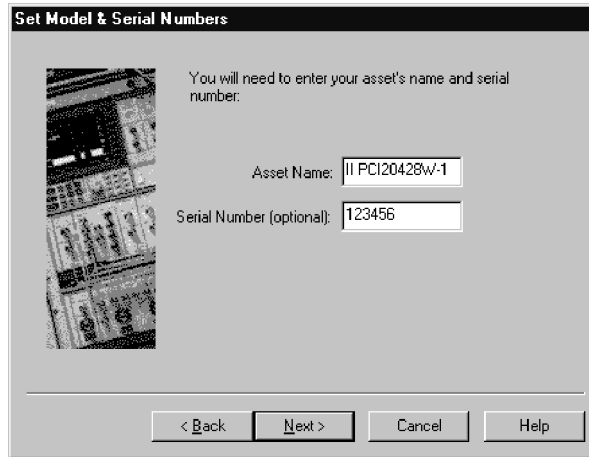

24. From the **Baseband Source** pulldown list, select **(internal)**. This designates the noise source on the PC Digitizer board as the noise source to be used for loop suppression verification.

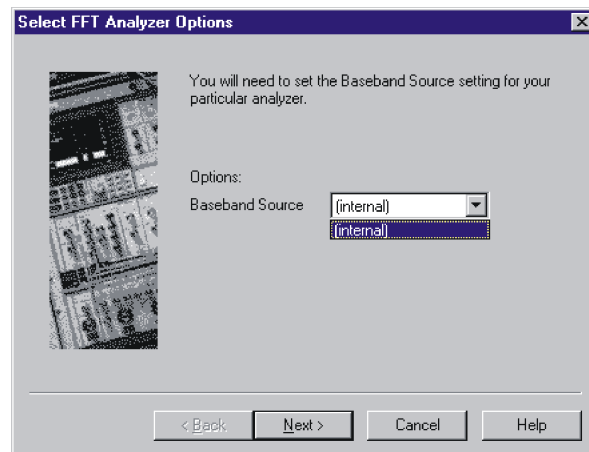

25. Click the **Next** button.

Welcome to the E5500B Phase Noise Measurement System Series of Solutions

26. You may type a comment in this dialog box. The comment will associate itself with the asset you have just configured. Click the **Finish** button.

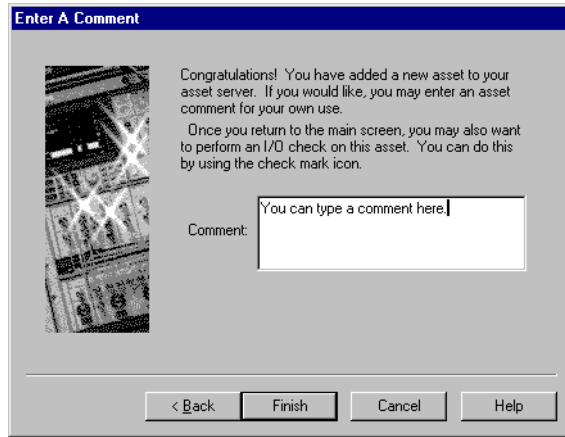

27. You have just used the Asset Manager to configure the PC-digitizer. The process you have used to configure both the Agilent/HP 70420A and PC-digitizer is the same process you will use to add software controlled assets to the phase noise measurement software.

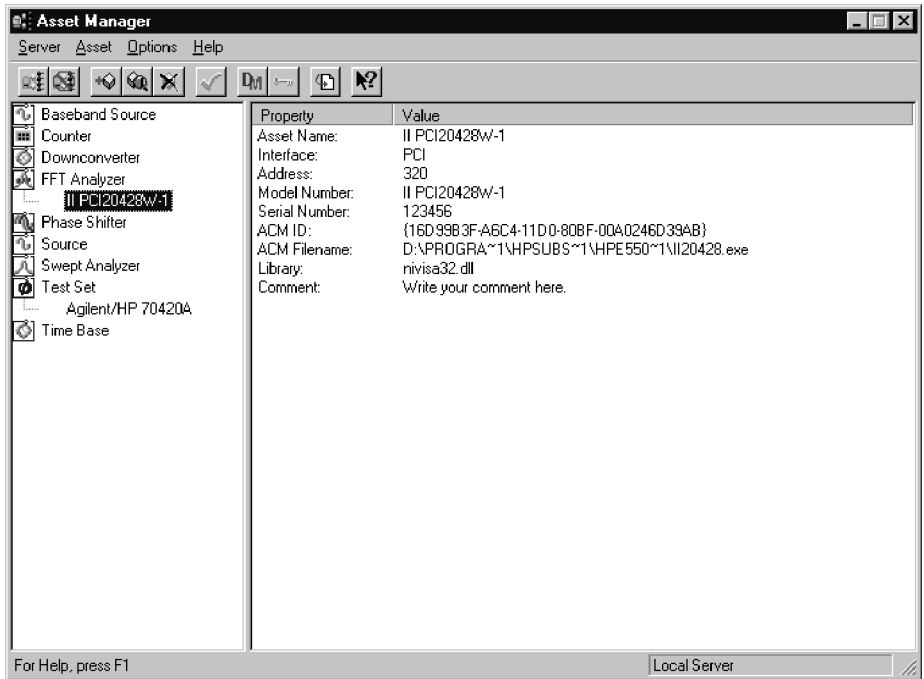

### Configuring the Agilent/HP E4411A/B (ESA-L1500A) Swept Analyzer

28. Follow the steps (7 through 15) that you used to configure the Agilent/HP 70420A Test Set to configure the Agilent/HP E4411A/B Swept Analyzer.
29. The default GPIB address for the Agilent/HP E4411A/B is 18.
30. Click **Server**, and then click **Exit** to exit the Asset Manager. Next we will enter the license key for the software.

### Default GPIB Addresses

The following default GPIB addresses are those pre-set at the factory.

*Table 1-3 Default GPIB Addresses*

Instrument	GPIB Address
Agilent/HP 70420A Test Set	20
Agilent/HP 70422A Downconverter	28
PC Digitizer	320
RF Analyzer	18
Source	19
Counter	3



---

## Step 8. Entering the License Key for the Phase Noise Test Set

Use the following procedure to enter your keyword for your Agilent/HP 70420A Phase Noise Test Set.

---

### NOTE

If you have ordered a preconfigured phase noise system from Agilent Technologies, skip this step and proceed to [“Step 9. Starting the Measurement Software”](#) on page 1-36.

1. Make sure your computer and monitor are turned on.
2. Click the **Start** button, point to **Programs**, point to **Agilent Subsystems**, point to **E5500 Phase Noise**, and then click **E5500 Asset Manager**.



# Welcome to the E5500B Phase Noise Measurement System Series of Solutions

3. click **Options**, and then click **License Keys**.

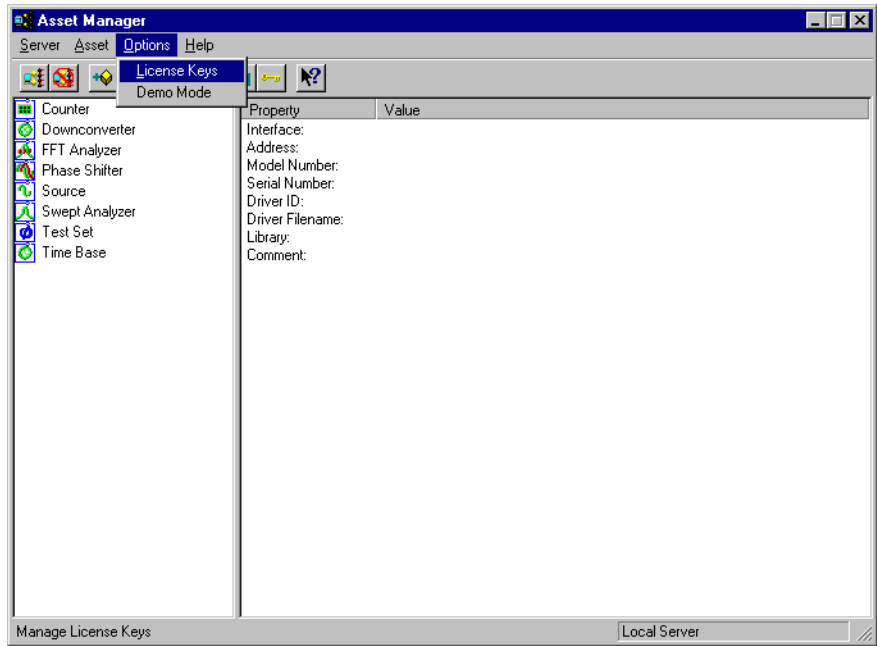

---

## NOTE

---

The license key for your system is unique and may only be used with a specific Agilent/HP 70420A Test Set serial number. The license key may be found both on your license-key document and in the file "license\_key.txt" on the License\_key floppy disk provided with your system.

Welcome to the E5500B Phase Noise Measurement System Series of Solutions

4. Enter the license key for your Agilent/HP 70420A Test Set and click the **Set** button. Use the License\_key.txt file described in the next step to facilitate entering your license key into the licensing dialog box.
  - a. Insert the E5500 License Key disk in the computer.
  - b. Using Notepad, load **License\_key.txt**.

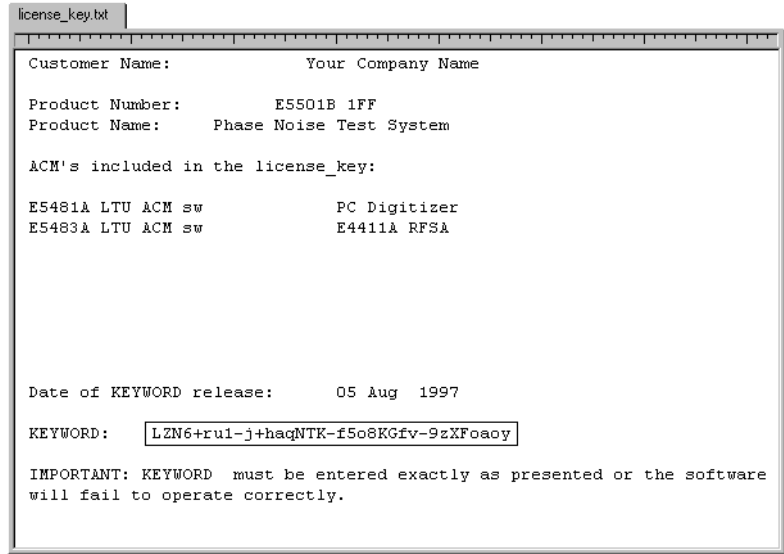

- c. Highlight the keyword in the License\_key.txt file and copy it to the dialog box shown below, then click the **Set** button.

For information about how to copy and paste information in Windows, refer to the Windows documentation or On-Line Help.

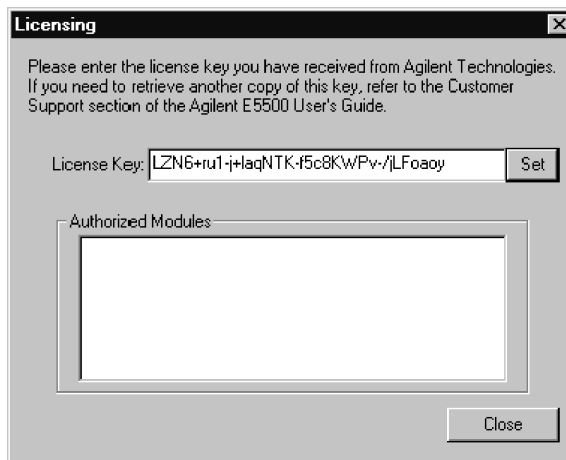

5. The next step is to start the measurement software.

---

## Step 9. Starting the Measurement Software

1. Make sure your computer and monitor are turned on.
2. Click the **Start** button, point to **Programs**, point to **Agilent Subsystems**, point to **E5500 Phase Noise**, and then click **E5500 User Interface**.

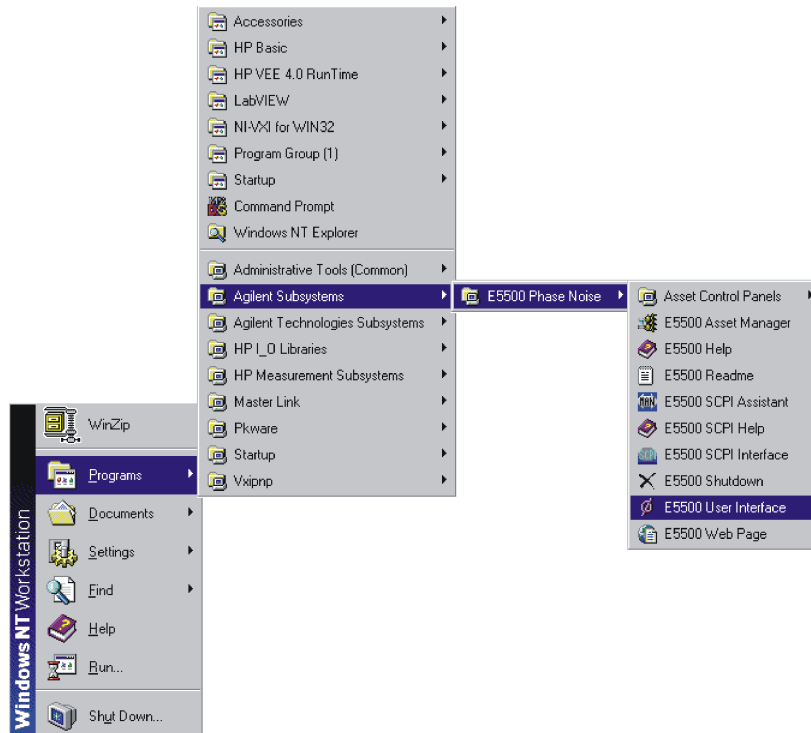

## Step 10. Using Server Hardware Connections to Specify Assets for the Confidence Test

1. From the **System** menu, choose **Server Hardware Connections**.

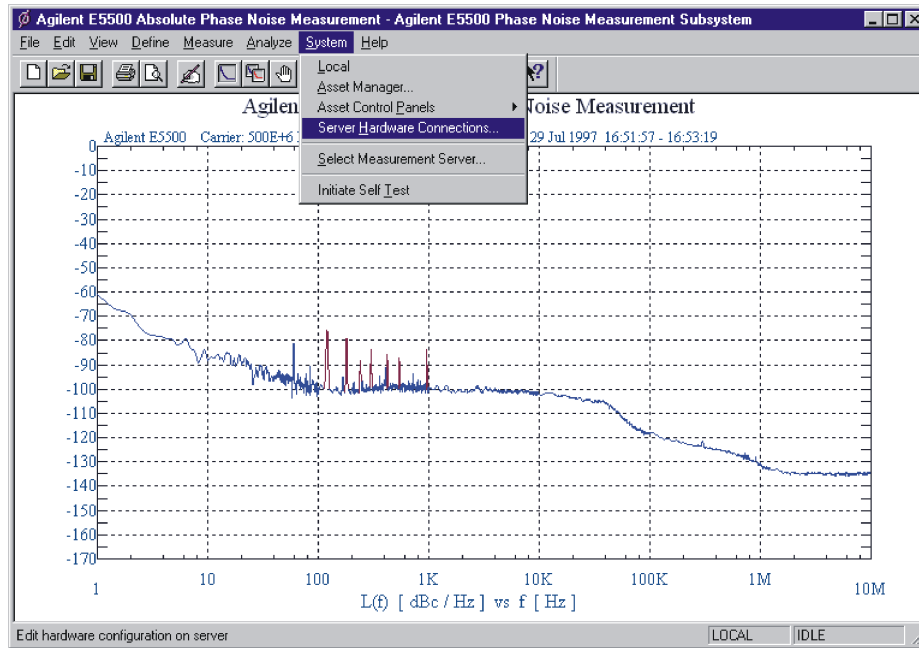

2. The following dialog box will appear.

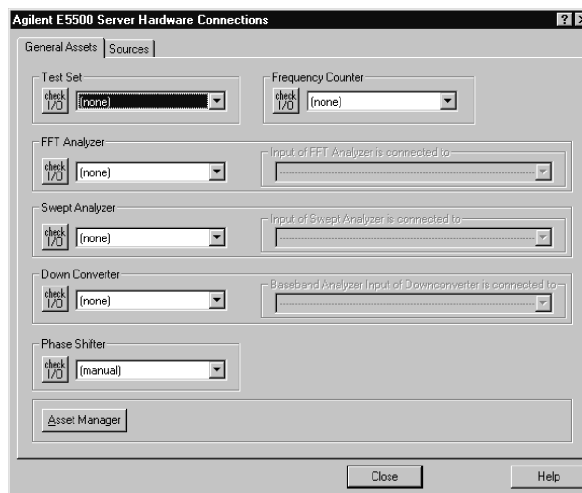

Welcome to the E5500B Phase Noise Measurement System Series of Solutions

- From the **Test Set** pull-down list, select **Agilent/HP 70420A**. Click the **Check I/O** button. A green check-mark will appear after the I/O check has been performed by the software. If a red circle with a slash appears, return to the Asset Manager (click the **Asset Manager** button) and verify that the Agilent/HP 70420A and PC-Digitizer are configured correctly (check that the license key has been entered correctly). Also check your system hardware connections. Click the **Check I/O** button for a re-check.

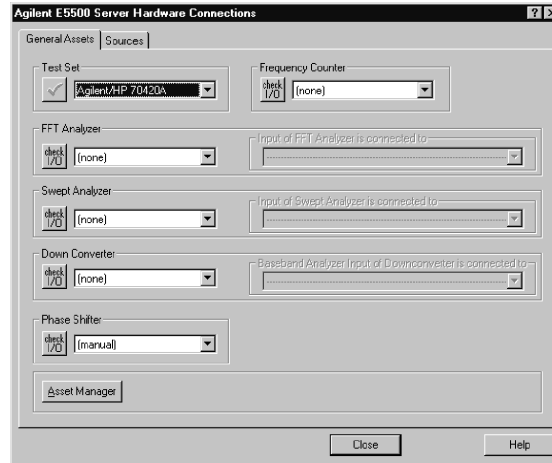

- From the **FFT Analyzer** pull-down list, select **II PCI20428W-1**. Click the **Check I/O** button. A green check-mark will appear after the I/O check has been performed by the software.
- From the **Swept Analyzer** pull down list select **E4411A**. Click the **Check I/O** button. A green check mark will appear after the I/O is completed.

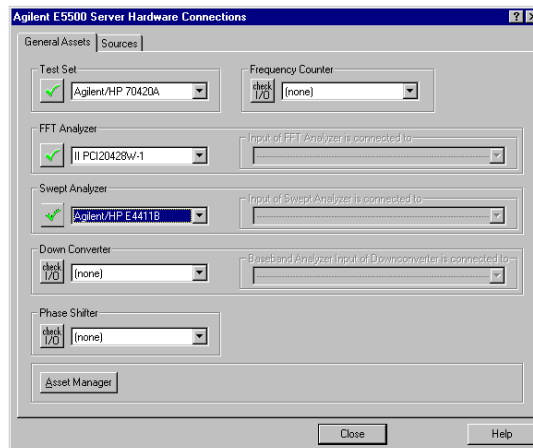

Selecting the Agilent/HP 70420A test set, the E4411A and the **II PCI20428** PC-digitizer will tie those assets to the confidence test we will be performing in the next step.

Click the **Close** button.

---

## Step 11. Running the Software Confidence Test

This measurement demonstration will introduce you to the system's operation by guiding you through an actual phase noise measurement.

This first measurement tests the Agilent/HP 70420A Test Set's low-noise amplifier circuitry. The phase detectors are not tested. This measurement will also confirm that the PC and test set are communicating with each other.

1. From the **File** menu, choose **Open**.

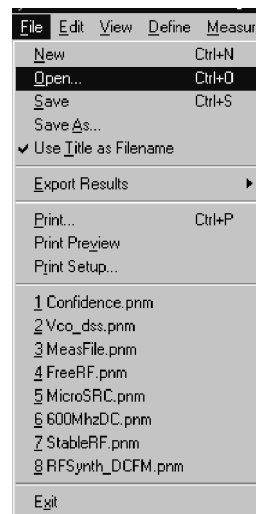

2. If necessary, choose the drive or directory where the file you want is stored.
3. In the **File Name** box, choose **Confidence.pnm**.

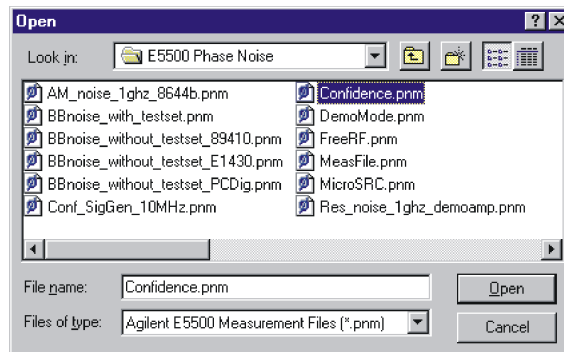

4. Click the **Open** button.

Welcome to the E5500B Phase Noise Measurement System Series of Solutions

The appropriate measurement definition parameters for this example have been pre-stored in this file. [Table 1-4 on page 1-40](#) lists the parameter data that has been entered for the Agilent/HP 70420A Confidence Test example.

**Table 1-4 Parameter Data for the Agilent/HP 70420A Confidence Test Example**

Step	Parameters	Data
1	<b>Type and Range Tab</b>	
	Measurement Type	• Baseband Noise (using a test set)
	• Start Frequency	• 10 Hz
	• Stop Frequency	• 100E + 6 Hz (determined by analyzer used)
	• Minimum Number of Averages	• 4
	FFT Quality	• Fast
	Swept Quality	• Fast
2	<b>Cal Tab</b>	
	• Gain preceding noise input	• 0 dB
3	<b>Block Diagram Tab</b>	
	• Noise Source	• Test Set Noise Input
4	<b>Test Set Tab</b>	
	Input Attenuation	• 0 dB
	LNA Low Pass Filter	• 20 MHz (Auto checked)
	• LNA Gain	• Auto Gain (Minimum Auto Gain - 14 dB)
	• DC Block	• Not checked
	• PLL Integrator Attenuation	• 0 dBm
	• Ignore out-of-lock conditions	• Not checked
	• Pulsed Carrier	• Not checked
5	<b>Graph Tab</b>	
	• Title	• Agilent E5500 Phase Noise System Confidence Test
	• Graph Type	• Base band noise (dBV/Hz)
	• X Scale Minimum	• 10 Hz
	• X Scale Maximum	• 100 E + 6 Hz
	• Y Scale Minimum	• 0 dBc/Hz
	• Y Scale Maximum	• - 200 dBc/Hz
	• Normalize trace data to a:	• 1 Hz bandwidth
	• Scale trace data to a new carrier frequency of	• 1 times the current carrier frequency
	• Shift trace data by	• 0 dB
	• Trace Smoothing Amount	• 0
	• Power present at input of DUT	• 0 dBm



## Beginning the Measurement

1. From the **Measure** menu, choose **New Measurement**.

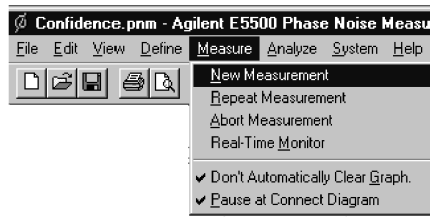

2. When the **Do you want to perform a New Calibration and Measurement** dialog box appears, click **OK**.

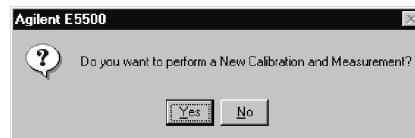

3. When the **Connect Diagram** dialog box appears, connect the 50  $\Omega$  termination provided with your system to the Agilent/HP 70420A Test Set's Noise Input connector. (See Figure 1-1.)

Since the System Confidence Test tests the Agilent/HP 70420A Test Set's low noise amplifier the following connect diagram does not apply.

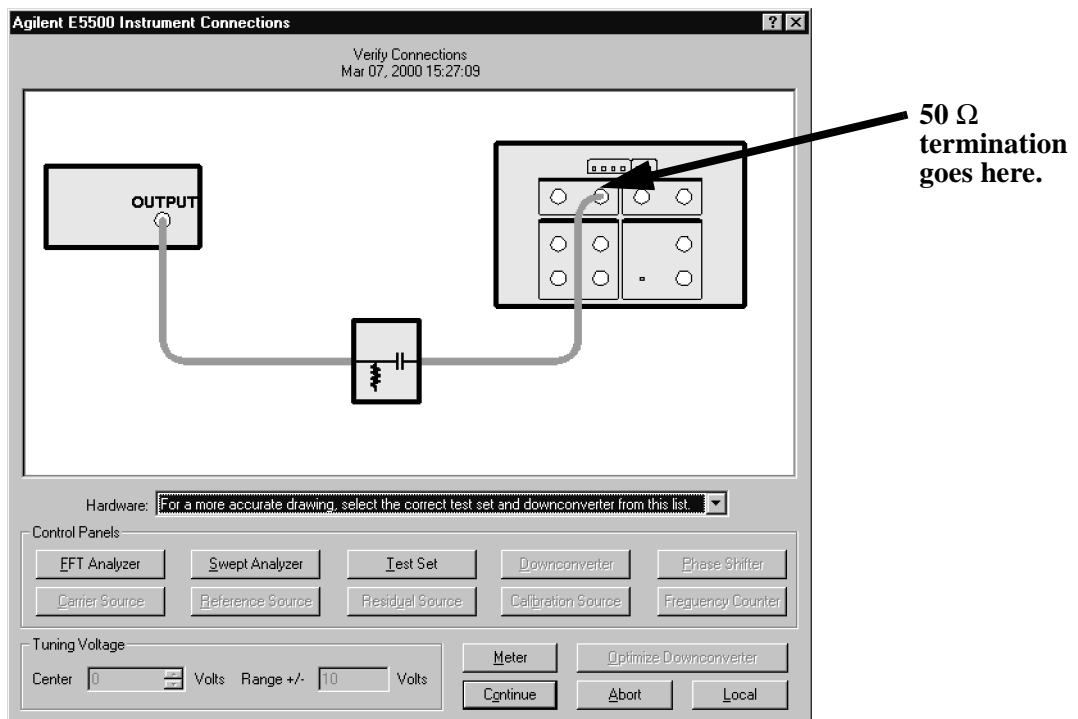
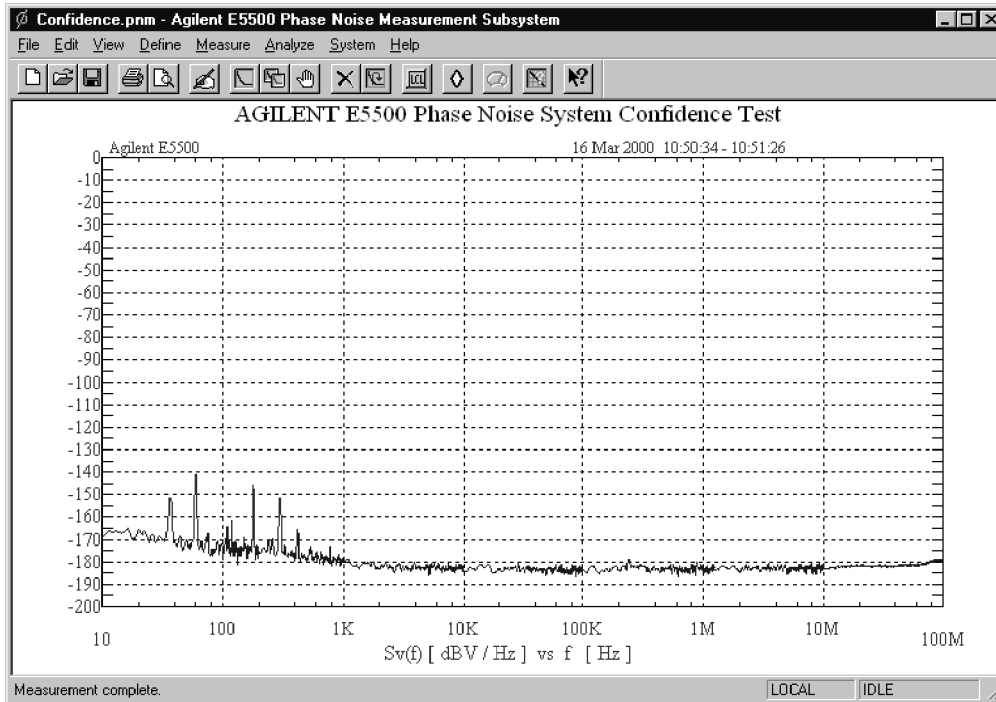

**Figure 1-1** System Confidence Test Connection Diagram.

## Making the Measurement

1. Press the **Continue** key. Because you selected New Measurement to begin this measurement, the System starts by running the routines required to calibrate the current measurement setup.

Figure 1-2 shows a typical baseband phase noise plot for an Agilent/HP 70420A Phase Noise Test Set.



*Figure 1-2 Typical Phase Noise Curve for a System Confidence Test.*

## Congratulations

You have completed a phase noise measurement. You will find that this measurement of the Agilent/HP 70420A Phase Noise Test Set's low noise amplifier circuitry provides a convenient way to verify that the System hardware and software are properly configured for making noise measurements.

---

# Index

## A

- accessing your computer's ISA slots, 1-8
- Asset Manager
  - Configuring your System, 1-23

## C

- computer cover
  - replacing, 1-13
- configuring your system
  - asset manager, 1-23
- connections
  - using server hardware, 1-37
- cover
  - removing computer's, 1-7

## E

- entering the license key, 1-33
- ESD precautions, 1-9

## H

- hardware
  - installing, 1-6

## I

- I/O libraries
  - installing, 1-16
- installation steps, 1-3
- installing the Agilent/HP I/O library upgrade, 1-17
- installing the hardware, 1-6
- installing the I/O libraries, 1-16
- installing the interface cards, 1-10
- installing the measurement software, 1-22
- installing the PC-Digitizer software, 1-19
- installing the Windows NT 4.0 Service Pack, 1-20
- interface cards
  - installing, 1-10
- ISA slots
  - accessing, 1-8

## L

- license key
  - entering, 1-33

## M

- measurement software
  - installing, 1-22
  - starting, 1-36

## N

- new measurement, 1-42

## P

- PC-Digitizer software
  - installing, 1-19
- precautions
  - ESD, 1-9

## R

- removing your computer's cover, 1-7
- replacing the computer cover, 1-13
- requirements
  - system, 1-4

## S

- starting the measurement software, 1-36
- steps
  - installation, 1-3
- system
  - confidence test, 1-39
  - unpacking, 1-5
- system confidence test, 1-39
- system requirements, 1-4

## U

- unpacking your system, 1-5
- upgrade
  - Agilent/HP I/O library, 1-17
- using server hardware connections, 1-37
- using this guide, 1-22

## W

- Windows NT 4.0 Service Pack
  - installing, 1-20